

- 1
- 2
- 3
- 4
- 5
- 6
- 7
- 8
- 9
- 10
- 11
- 12
- 13
- 14
- 15
- 16
- 17
- 18

MATERIAL

Cast aluminium with epoxy resin coating, matte finish.

CENTRE CAP

Glass-fibre reinforced polyamide-based (PA) technopolymer, colour light grey.

STANDARD EXECUTION

H7 reamed hole.
 Fold-away handle in polyamide based (PA) technopolymer, black colour, matte finish.
 Colour index:
 - **SW**: RAL 9005 black colour.
 - **SR**: RAL 9006 light grey colour.

ACCESSORIES ON REQUEST

Axial retaining washer GN 184 (see page 677).

SPECIAL EXECUTIONS ON REQUEST

Handwheels with keyway in compliance with DIN 6885/1 tolerance P9 (see page A-16).

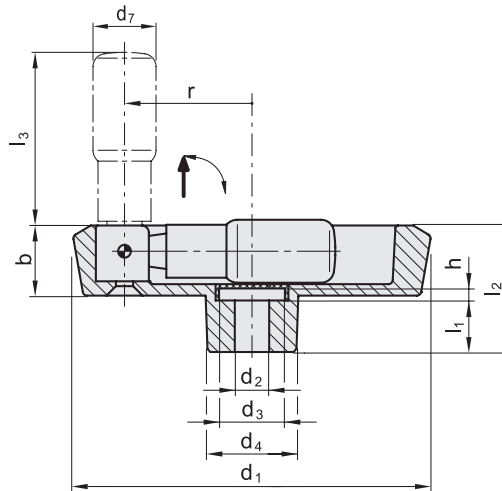

Conversion Table	
1 mm = 0.039 inch	
d1	
mm	inch
100	3.94
125	4.92
140	5.51
160	6.30
200	7.87

METRIC

GN 923.3

Code	Description	d1	d2 H7	d3	d4	b	h	l1	l2	l3	r	d7	Washer	△
GN.68182	GN 923.3-100-B10-R-SW	100	10	18	28	20	4	17	39	56.5	35	18	GN 184-16	252
GN.68184	GN 923.3-100-B12-R-SW	100	12	18	28	20	4	17	39	56.5	35	18	GN 184-16	260
GN.68186	GN 923.3-125-B12-R-SW	125	12	23	31	24.5	4	18	45	60.5	44.5	22	GN 184-22	460
GN.68188	GN 923.3-125-B14-R-SW	125	14	23	31	24.5	4	18	45	60.5	44.5	22	GN 184-22	440
GN.68190	GN 923.3-140-B14-R-SW	140	14	23	36	26	4	19	47	75.5	52	24	GN 184-22	590
GN.68192	GN 923.3-140-B16-R-SW	140	16	23	36	26	4	19	47	75.5	52	24	GN 184-22	550
GN.68194	GN 923.3-160-B14-R-SW	160	14	23	36	26	4	20	48	75.5	61	24	GN 184-22	740
GN.68196	GN 923.3-160-B16-R-SW	160	16	23	36	26	4	20	48	75.5	61	24	GN 184-22	730
GN.68198	GN 923.3-200-B18-R-SW	200	18	23	42	27	4	24	53	85.5	80.5	25	GN 184-22	1100
GN.68200	GN 923.3-200-B20-R-SW	200	20	23	42	27	4	24	53	85.5	80.5	25	GN 184-22	921
GN.68181	GN 923.3-100-B10-R-SR	100	10	18	28	20	4	17	39	56.5	35	18	GN 184-16	252
GN.68183	GN 923.3-100-B12-R-SR	100	12	18	28	20	4	17	39	56.5	35	18	GN 184-16	260
GN.68185	GN 923.3-125-B12-R-SR	125	12	23	31	24.5	4	18	45	60.5	44.5	22	GN 184-22	460
GN.68187	GN 923.3-125-B14-R-SR	125	14	23	31	24.5	4	18	45	60.5	44.5	22	GN 184-22	440
GN.68189	GN 923.3-140-B14-R-SR	140	14	23	36	26	4	19	47	75.5	52	24	GN 184-22	590
GN.68191	GN 923.3-140-B16-R-SR	140	16	23	36	26	4	19	47	75.5	52	24	GN 184-22	550
GN.68193	GN 923.3-160-B14-R-SR	160	14	23	36	26	4	20	48	75.5	61	24	GN 184-22	740
GN.68195	GN 923.3-160-B16-R-SR	160	16	23	36	26	4	20	48	75.5	61	24	GN 184-22	730
GN.68197	GN 923.3-200-B18-R-SR	200	18	23	42	27	4	24	53	85.5	80.5	25	GN 184-22	1100
GN.68199	GN 923.3-200-B20-R-SR	200	20	23	42	27	4	24	53	85.5	80.5	25	GN 184-22	921

Handwheels and crank handles